

After many years of R&D and following the success of its X-PRO Series System, COKIN is proud to introduce its new **Z-PRO Holder**.



**1**

Applications are **FILM & DIGITAL**,  
D-SLRs, Video & Broadcast cameras

The new **Z-PRO Filter-Holder** is designed to fit both **FILM** and **DIGITAL** technologies in particular **D-SLRs** and **VIDEO/ BROADCAST** cameras, either semi-professional or professional models (among them the new HD format).

**2**

Totally Modular

It is modular, it can be easily dismantled and set-up to be able to accept filters of 1.6mm thickness (which most photographers use), and 4.0mm thickness (often used in the Broadcast segment in popular dimensions such as 100x100mm (4"x4") and 100x150mm (4"x6")).

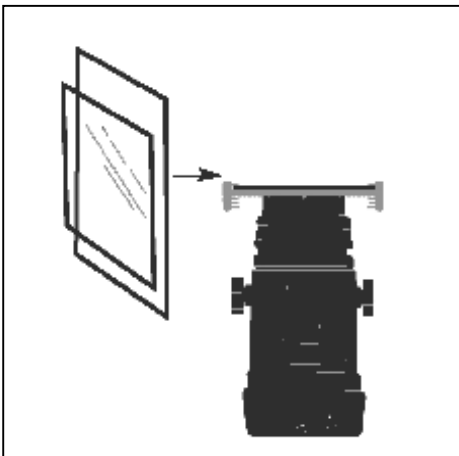
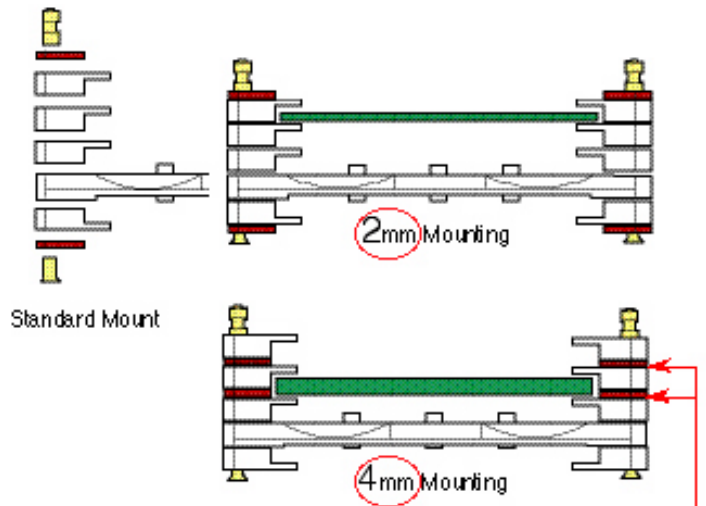

**3**

Reversible Holder



To prevent the risk of vignetting (dark edges around the picture), the Z-PRO series filter-holder is **fully reversible**, which means that a filter can fit in the adaptor ring's slot and the adaptor ring can be fit in the first filter slot. Therefore the filter can be positioned very close to the lens and the edges of the holder are no longer an obstacle in the field of view.

## 4 Eliminates vignetting over 20mm focal lengths

The Z-PRO filter-holder was tested (in the standard 3-slot version) and proved **no vignetting** on focal lengths down to 20mm (based on 35mm format) but of course, this can go further wide in the wide-angle configurations.

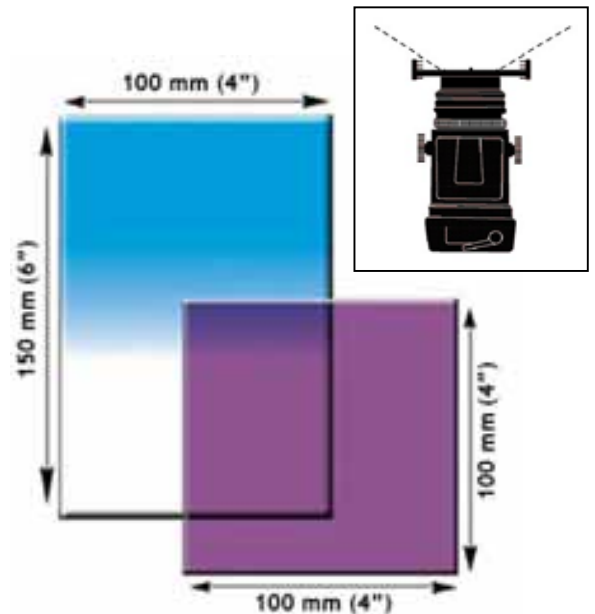

## 5 Fits lenses up to 96mm filter diameter

The Z-PRO filter-holder will fit a large variety of lenses thanks to a range of adaptor rings covering the popular diameters of 49mm up to 96mm. Additional rings designed for Hasselblad® B60/B70 and Rollei® are also available.

## 6 Perfect performance with DIGITAL TECHNOLOGY

The entire Z-PRO system is ideal to work with the newest generation of **Digital SLR** and **Video** cameras.

## 7 Reminder on the Z-PRO range:

The Z-PRO range of filters is made of organic glass with a very high optical transmission. It includes over **90 different filters** designed to satisfy the needs of Pro Photographers and Videographers – including Correction/Conversion filters, Graduated filters, filters for Black & White, Soft filters, Neutral Density filters, etc.

The Z-PRO range also includes a **storage wallet** for 5 filters (ref. Z306) and **two filter kits** with graduated filters selected from the most widely used versions:



### Z-PRO Filter Kits

- ① Ref.U960 – **Pro Grad Kit** = filter-holder + Z121L + Z123L + Z125L + wallet Z306
- ② Ref.U961 – **Pro Grad ND Kit** = filter-holder + Z121L + Z121M + Z121S + wallet Z306  
= (ND2) (ND4) (ND8)

